



FOREST CS[®] CONTRACT SYSTEM



MANUAL
CONTROL



RECESS
OPTION



HOTEL
TRACK

Heavy duty hand drawn curtain track system for medium and heavy draperies.

FOREST CS[®]
FOREST CS[®] RECESS

NEW!



THE WORLD
BEHIND
YOUR
CURTAINS



PRODUCT INFORMATION

- Heavy duty hand drawn system for medium and heavy draperies.
- Bendable; it can be bent and reverse bent using a 20 cm (8") radius or continuous curve.
- Heavy duty clickable carriers - 10 carriers on a breakaway strip - UV protected. Can also be used with ball bearing carriers.
- Ideal for use with overlap masters and batons which can be mounted behind or in front of draperies.
- Can also be used for the Forest Wave System (FES) and accordiafold drapery systems.
- Maximum fabric weight: CS: 15 kg p/m, CS Recess: 10 kg p/m.
- Colours available: white, black and grey.
- Track finish: High quality aluminium, powder coated with a factory applied patented dry lubricant.
- Available lengths: 3.66 m (12'), 4.27 m (14'), 4.88 m (16'), 6.10 m (20')
- Warranty: 10 years.

- 1 CS Track
- 2 Carrier
- 3 Master Carrier R/L Overlap
- 4 Master Carrier R/L Underlap
- 5 Ball bearing carrier
- 6 Endcap with screw

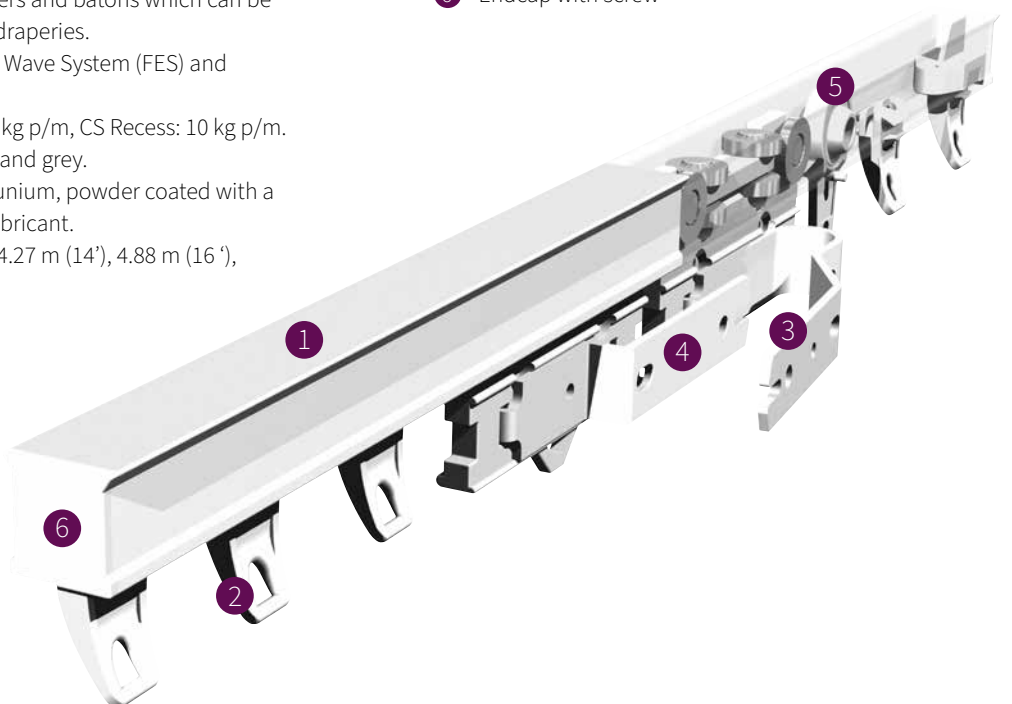



CS RECESS

Our CS® is now also offered as the CS® Recess model. Special care and attention have been given to the track joining method and endcaps. The CS® Recess brings a touch of luxury to any space with its seamless ceiling integration, providing a refined and graceful finish. Equipped with the innovative silent roller glider, it ensures ultra-smooth and whisper-quiet curtain operation. Available in matt white and matt black.

BENDING / CURVING

The CS® and CS® Recess can bent and reverse bent using a 20 cm (8") radius. Continuous curving is also possible with the electrical bending tool (only possible with CS rail).



APPLICATIONS

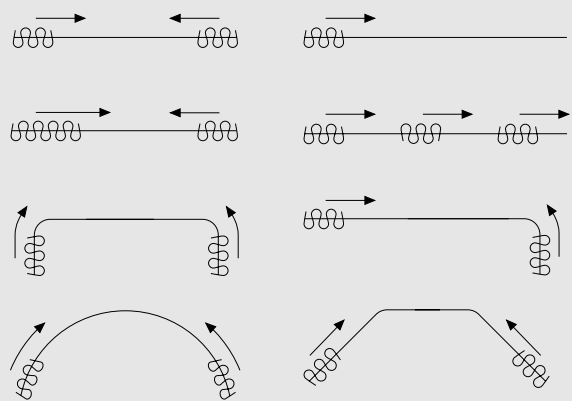

FEATURES

CS:

- Weight: 235 gr/mtr (2.53 ounce - ft)
- 20 mm x 20 mm (0,8" x 0,8")
- Aluminium Extrusion

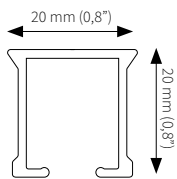

CS Inbouw:

- Weight: 385 gr/mtr (4.14 ounce - ft)
- 23 x 23 mm (0,9" x 0,9")
- Pre-drilled: holes every 25 cm

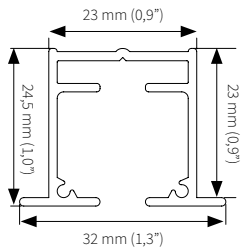

FOR USE IN

Hotels - motels - offices - schools - healthcare residential or at any location where a heavy duty hand drawn system is required.

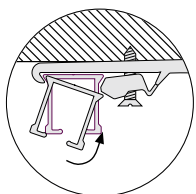

Easy installation
click - position - tighten

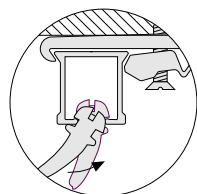

clickable carrier

38 mm (1,5")

CLICK-ON STIFFENER

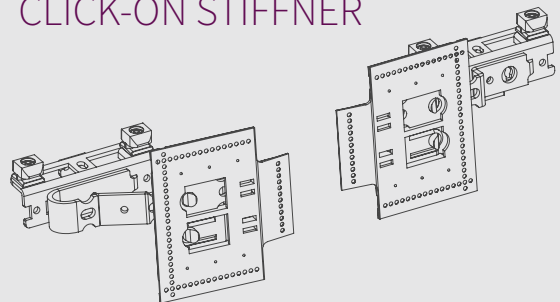

For applications where the curtains are treated very roughly, the stiffener is a sustainable solution. The stiffener makes curtains more robust and ensures that curtains last longer. Especially useful for hotels.

MOUNTING BRACKETS

Smart Klick Ceiling bracket

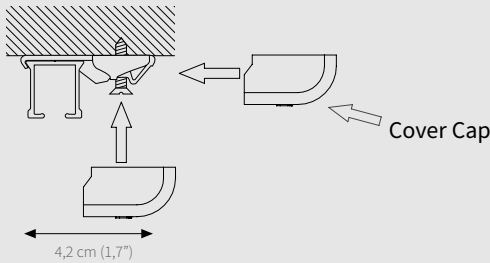

A) Min. 7,5 cm (2,9\"/>



A) Min. 15 cm (5,9\"/>

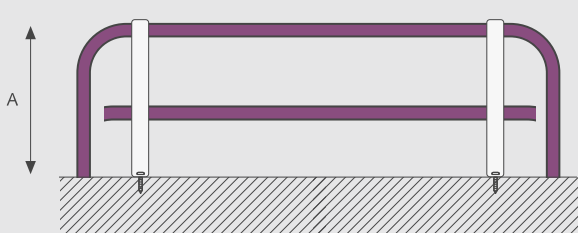

Other brackets are available. Brackets need to be placed every 60 cm (24\"/>

SK Aluminium Wall bracket single

- A) 7,5 cm (3\"/>

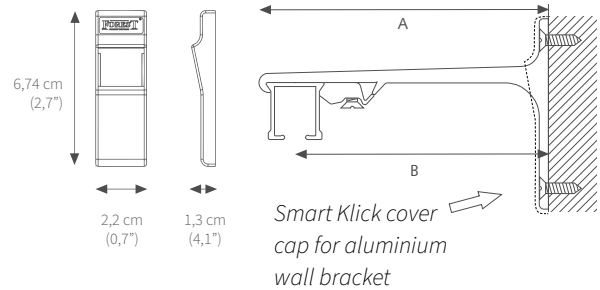

SK Aluminium Wall bracket double

- A) 15 cm (6\"/>

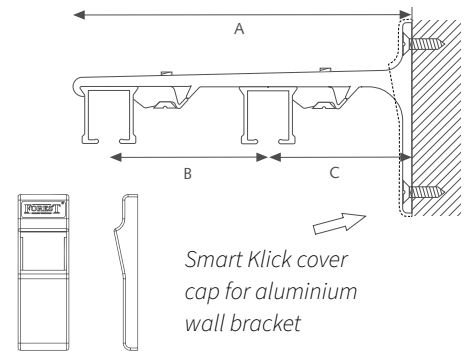

SK Aluminium Wall bracket triple

- A) 25 cm (10\"/>

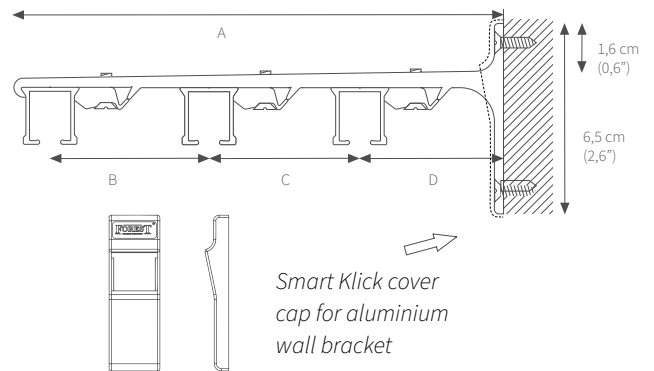

Brackets need to be placed every 50 - 60 cm (20\"/>









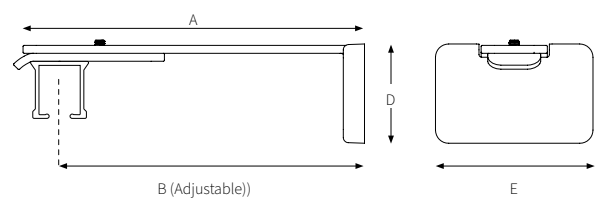

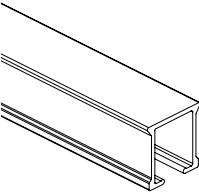
Adjustable Wall Bracket

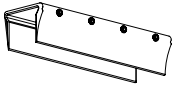
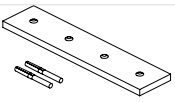
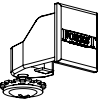
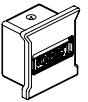
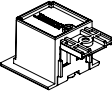



8 cm (3,1\"/>

A = 8,9 (3,5\"/>

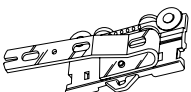

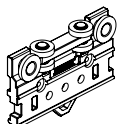
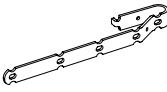
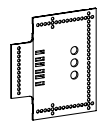
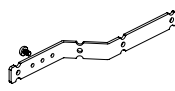
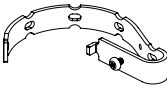

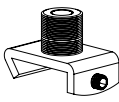
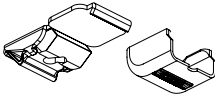
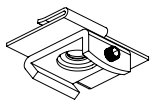
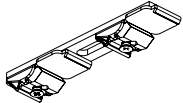
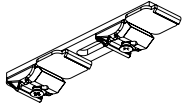
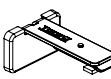
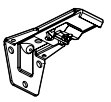
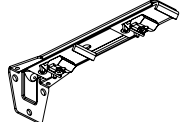

D = 3,75 (1,5\"/>

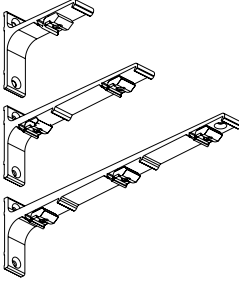
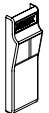
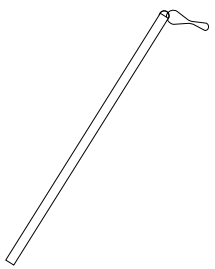
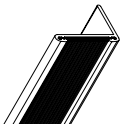
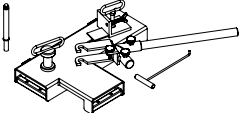
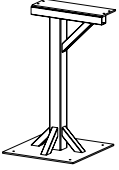
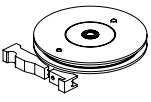
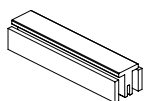
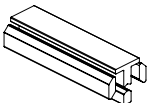

CS	CS RECESS	ARTICLE	PACKING UNIT	ART.NR		
●			CS TRACK WHITE Extruded aluminium, powder coating, factory lubricated	10/bundle	3,66 meter (12') 4,27 meter (14') 4,88 meter (16') 6,10 meter (20')	2501001366 2501001427 2501001488 2501001610
			CS TRACK GREY Extruded aluminium, powder coating, factory lubricated	10/bundle	6,10 meter (20')	2501003610
			CS TRACK BLACK Extruded aluminium, powder coating, factory lubricated	10/bundle	6,10 meter (20')	2501006610
	●		CS RECESS TRACK 6 mtr	10/bundle	matt white matt black	2531011600-MAT 2531016600-MAT
●			CS/CCS/FMS TRACK CONNECTOR Used to make a solid connection between two pieces of track	10/box	white matt white grey black matt black	2518401000-A 2518401000-A-M 2518403000-A 2518406000-A 2518406000-A-M
	●		CS RECESS TRACK CONNECTOR GALVANISED SET	1/bag		2530401000
●			CS ENDCAP UNIVERSAL LONG WITH SCREW	100/box	white grey black	2516400000 2516403000 2516406000
●			CS ENDCAP UNIVERSAL SHORT WITH SCREW	100/box	white grey black	2516401001 2516403001 2516406001
	●		CS RECESS END CAP LONG Metal, powder coated	1/ doos	mat wit mat zwart	2536401000-MAT 2536406000-MAT
	●		CS RECESS END CAP SHORT Metal, powder coated	1/ doos	mat wit mat zwart	2536401001-MAT 2536406001-MAT
●	●		CS / CS RECESS / CCS AS CARRIER Clickable, offset, constructed of UV-resistant plastic. 10 Carriers on a break-away strip. Can be clicked in after	250/box	white grey black	2510101000 2510103000 2510106000
●			CS STOPCARRIER Clickable	100/box	white	2510201000
●			CS / CCS CARRIER AS WITH HOOK Clickable	100/box	white	2510501000
●			CS ECONOMY SLIDE Can turn in the track	500/box 500/box	white black	2510601000 2510606000
●			CS BALL BEARING CARRIER 16MM SMALL	100/box	white black	2512000016 2512006016
●	●		CONTRACT ROLLER CARRIER For a silent and smoothly operation with heavier curtains, also for CS Recess. Designed for use with butterfly pleats	100/box	white black	4831001000 4831006000
●			CS UNDERLAP CARRIER R/L	25/box	white	2514600000
●			CS OVERLAP CARRIER R/L	25/box	white	2514700000

CS	CS RECESS	ARTICLE	PACKING UNIT	ART.NR
•		 CS MASTER CARRIER BASE R/L WHITE	25/box	white 481450000
•		 PROLONGED OVERLAP ARM 150MM R/L for click-on stiffener	15/box	white 9500001010
•		 STIFFNER "CLICK-ON"	15/box	5116001001
•		 Z-ARM UNIVERSAL 175MM R/L Ideal for blackout	15/box	white black 9500001030 9500006030
•		 FMS EASYFLEX CURVED ARM R/L WHITE	15/box	white black 5135901020 5135906020
•		 MTS SUSPENSION CEILING BRACKET Length: 10 cm (4") - 100 cm (40") Complete with MTS Insert Screw and MTS Top Piece	1/each	white 4518201000
•		 MTS SUSPENSION CEILING BRACKET 1,50 MTR WHITE Length: 100 cm (40") - 150 cm (59") Complete with MTS insert screw and MTS Top Piece	1/each	white black 4518201500 4518206150
•		 MTS SUSPENSION CEILING BRACKET 2,00 MTR WHITE Length: 200 cm (78") Complete with MTS insert screw and MTS Top Piece	1/each	white 4518202000
•		 SUSPENSION BRACKET CLIP FOR KS For CS, to be used in combination with the MTS Suspension Ceiling Bracket.	50/box	white black 1016901000 1016906000
•		 SMART KLICK CEILING BRACKET INCL COVER CAP "Klicks" onto track, powder coated.	100/box	white grey black 1018201001 1018203001 1018206001
•		 FALSE CEILING BRACKET (METAL) For installation on to a suspended ceiling. The track can be fixed in any angle.	25/box	white black 4519001000 4519006000
•		 SMART KLICK CEILING BRACKET DOUBLE LONG Distance between two tracks: 90 mm (3,5")	30/box	white black 1018601000 1018606000
•		 SMART KLICK CEILING BRACKET DOUBLE SHORT		1018611000
•		 ADJUSTABLE WALL BRACKET 8 CM INCL. COVER	2/box	white matt white grey matt black 1020901080 1020901080-mat 1020903080 1020906080-mat
•		 KS ADJUSTABLE WALL BRACKET, SINGLE 7,5 - 11,5 cm	100/box	white grey 1020801115 1020803115
•		 KS ADJUSTABLE WALL BRACKET, DOUBLE 6,5 - 19,5 cm	50/box	white 1020801195

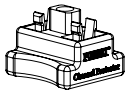
CS	CS RECESS	ARTICLE	PACKING UNIT		ART.NR	
•			ALUMINIUM WALL BRACKET 7.5 cm single (3')	20/box	white grey black	1020301075 1020303075 1020306075
			ALUMINIUM WALL BRACKET 10 cm single (4')	20/box	white grey black	1020301100 1020303100 1020306100
			ALUMINIUM WALL BRACKET 15 cm double (6')	15/box	white grey black	1020301150 1020303150 1020306150
			ALUMINIUM WALL BRACKET 20 cm double (8')	15/box	white grey black	1020301200 1020303200 1020306200
			ALUMINIUM WALL BRACKET 25 cm triple (10')	15/box	white grey black	1020301250 1020303250 1020306250
•			COVER CAP FOR SMART KLICK ALUMINIUM WALL BRACKET	50/box	white grey black	1021301000 1021303000 1021306000
•	•		FLICKSTICK FIBERGLASS	50/box	92 cm 122 cm 152 cm	1065101092 1065101122 1065101152
			FLICKSTICK TRANSPARENT	50/box	92 cm 122 cm 152 cm	1065102092 1065102122 1065102152
			FLICKSTICK WHITE ALUMINIUM	50/box	92 cm 122 cm 152 cm 202 cm	1065111092 1065111122 1065111152 1065111202
			FLICKSTICK SILVER ALUMINIUM	50/box	92 cm 122 cm 152 cm	1065113092 1065113122 1065113152
			FLICKSTICK BLACK ALUMINIUM	50/box	92 cm 122 cm 152 cm	1065116092 1065116122 1065116152
			FLICKSTICK ANTIQUE ALUMINIUM	50/box	92 cm 122 cm 152 cm	1065119092 1065119122 1065119152
•	•		VELCRO HOTEL PROFILE Inside frame fix, to reduce light leakage in combination with Looptape	120 mtr/bundle		3581601600
			LOOPTAPE	25 mtr/roll		
•	•		CONTRACT BENDING TOOL BASIC (without bending wheel)	1/each		2560000000
•			BENDING STAND Stand for contract bending tool	1/each		2560800000
	•		CS RECESS BENDING WHEEL + 2 WEDGES	1/set		2530000000
			CS/CCS/FMS BENDING WHEEL	1/each		
•			CS/FMS BENDING STRIPS For CS track, length: 90 cm (35,4")	1/set		8500000001
			CS/FMS BENDING STRIP FOR ELECTRIC POWERED BENDER Length 7 meter (23')	1/piece		
	•		CS RECESS BENDING STRIP SET 100 CM	1/set		2530000001

CS	CS RECESS	ARTICLE	PACKING UNIT	ART.NR	
•		 <p>ELECTRIC POWERED BENDER Available in 230V or 115V To create continuous curves and arches minimum radius 50 cm (20")</p>	1/each	1060500000	
•		 <p>CS/CCS BENDING WHEELS For Electric Powered Bender. Complete set of 3 wheels</p>	1/set	2560700000	
•	•	<p>example image</p>  <p>ELECTRIC POWERED RAILCUTTER 230 Volt EU</p> <p>BLADE FOREST CUTTER NEW MODEL</p>	1/each	1061100000	
•	•	 <p>FOREST LUBRICANT To lubricate components during assembly</p>	1/each	5109010000	
	•	 <p>MTS FLEXIBLE DUST STRIP To seal the curtain track opening of the ks recess track during finishing phase</p>	50 mtr/roll	4518501000	
	•	 <p>CHANNEL PROTECTOR with bit</p>	1/set	purple	1070600000
	•	 <p>SCREW M3 X 25MM FOR KS/CS RECESS PROFILE STAINLESS STEEL</p>	250/box	Forest073	

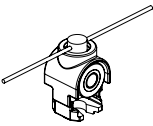
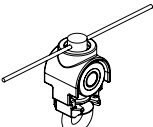
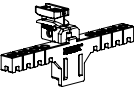
CS	CS RECESS	GENERAL WAVE COMPONENTS	ARTICLE	PACKING UNIT	ART.NR	
•	•		<p>CONTRACT EASYFOLD BASE ROLLER 60% 80MM For a silent and smoothly operation on CS, CS Recess, FMS Dual and CRS 28mm</p>	500/roll	white black	4833001060 4833006060
			<p>CONTRACT EASYFOLD BASE ROLLER 80% 60MM For a silent and smoothly operation on CS, CS Recess, FMS Dual and CRS 28mm</p>		white black	4833001080 4833006080
•	•		<p>CONTRACT EASYWAVE ROLLER 60% 80MM For a silent and smoothly operation on CS, CS Recess, FMS Dual and CRS 28mm</p>	500/roll	white black	4832001060 4832006060
			<p>CONTRACT EASYWAVE ROLLER 80% 60MM For a silent and smoothly operation on CS, CS Recess, FMS Dual and CRS 28mm</p>		white black	4832001080 4832006080
•	•		<p>WAVE ADJUSTABLE MASTER CARRIER For use with wave pleat curtains (Easyflex)</p>	25/box	white black	4813001050 4813006050
•	•		<p>WAVE ADJUSTABLE ENDSTOP For use with wave pleat curtains (FES). Height adjustable and blocks detachable for the correct wave pleat depth</p>	25/box	white black	4816001001 4816006001