



FOREST ROMAN BLIND SERIES



SMART HOME



APP CONTROL



REMOTE CONTROL



CHAIN CONTROL

Elegantly shaped aluminium profile with integrated Velcro Tape.

FOREST BS[®] MANUAL
FOREST BS[®] MOTOR (WIRED/BATTERY POWERED)
FOREST BS[®] MAX
FOREST BCS[®]

THE WORLD
BEHIND
YOUR
CURTAINS



FOREST BLIND SYSTEM - BS®



For a more streamlined look or when space is at a premium, roman blinds that stack neatly at the top of the window when retracted are the perfect solution. With the Blind System - BS® of Forest a sleek natural look is provided for your interior. Experience the simplicity of chain operation for Roman blinds. With an easy-to-use chain mechanism, adjusting the blinds to your desired position is effortless.

The Blind System - BS® is the most widely used and recognised roman blind in the industry. It comes with integrated velcro tape so that the fabric can be easily attached & removed. The system is always correctly aligned due to the twistlock on the cord roll support. For the ultimate convenience a motorised control option is possible. Operate the Blind System at the press of a button or by your smartphone. See for more info about motorised options check further down in this brochure.

CONTROL OPTIONS



SMART HOME



APP CONTROL



REMOTE CONTROL



CHAIN CONTROL

PRODUCT INFORMATION

- Compact hand drawn roman blind system.
- For all types of light and medium weight draperies.
- Elegant shaped aluminium profile, with integrated Velcro hook tape.
- Application width: min. 38 cm & max 5.80 meter (19").
- Available height: 3.50 meter (11.5").
- Simple face-fix and top fix installation.
- Conic shaped drums; thus smooth and straight operation of the system is guaranteed.
- Control unit options:
 - 1:1 (fabric weight up to 3,5 kg)
 - 1:4 (fabric weight up to 7,5 kg)
- Total maximum fabric weight up to 7,5 kg.
- Colour available: white.
- Special Child Safety solution possible (1:4 & 1:4).
- Track finish: durable, high-quality aluminium with a powder-coated finish.
- Warranty Manual System: 10 year.

FOR USE IN

Hotels, offices, residences, boats or anywhere an efficient Velcro track system for roman shades is required.

FEATURES

- Weight 409 gr/mtr
- Aluminium extrusion 6063 T5
- Size 33.3 x 36.7 mm (1.3" x 1.4")
- Colour available: white

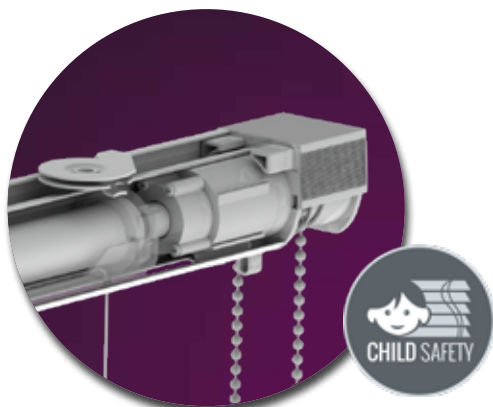
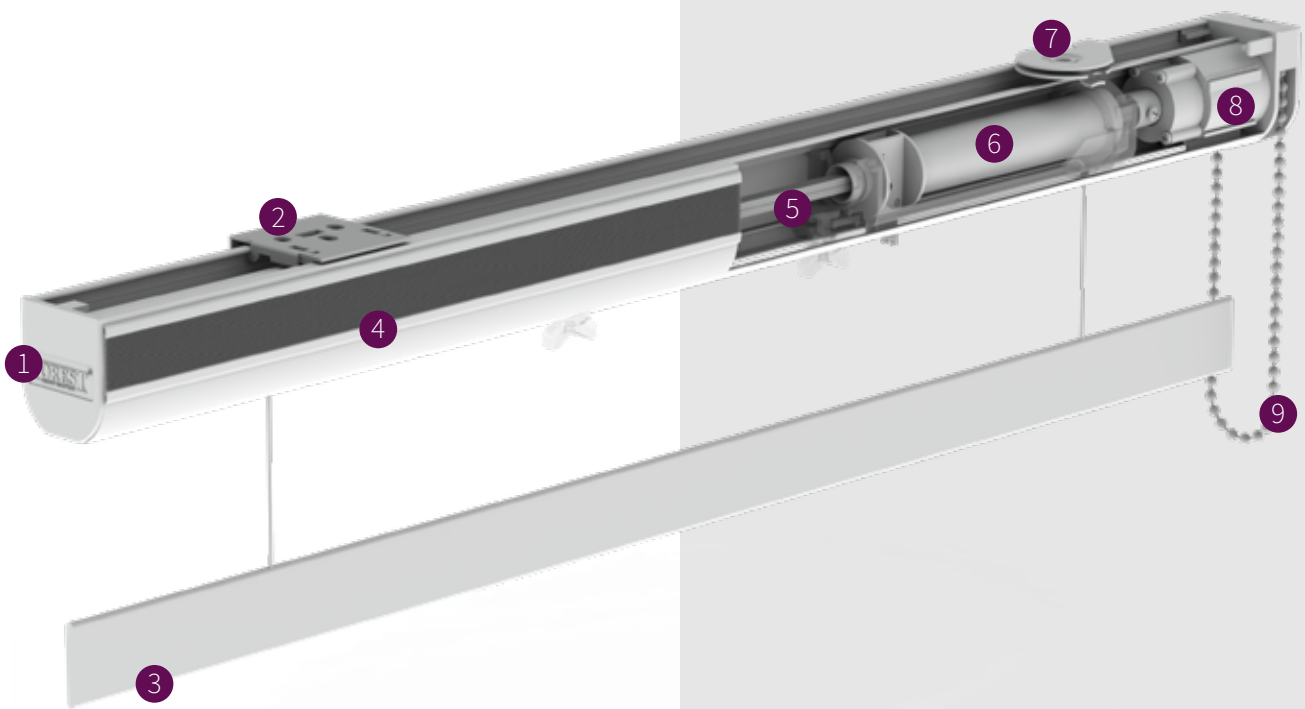
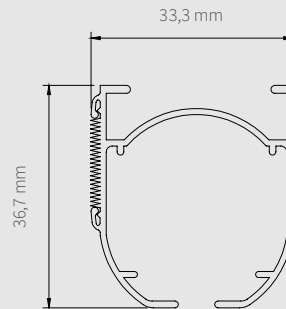

- ① BS Endcap
- ② BS Smart Klick® Ceiling / Wall Bracket
- ③ Counterweight bar 6 x 20 mm.
- ④ BS Track incl. Velcro Hook Tape
- ⑤ BS Rod 5x5mm
- ⑥ BS Quicklock Cord Roll
- ⑦ BS Ceiling bracket, swivel
- ⑧ BS Control Unit 1:4
- ⑨ Chain

FOREST BS[®] MOTOR (WIRED/BATTERY)



The Blind System - BS[®] is the most widely used and recognised roman blind in the industry. It comes with integrated velcro tape so that the fabric can be easily attached & removed. The system is always correctly aligned due to the twistlock on the cord roll support. For the ultimate convenience a motorised control option is possible. Operate the Blind System at the press of a button or by your smartphone.

The Bluetooth capabilities of this system works with our Forest Connect App, this feature separates it from the current industry offering.

Discover the convenience and elegance of battery-powered BS[®] Roman blind system. Enjoy the luxury of motorised blinds without the hassle of complex wiring. Effortlessly operate them using a switch or remote control or by app, adding a touch of sophistication to your space.

CONTROL OPTIONS



SMART HOME



APP CONTROL



REMOTE CONTROL

PRODUCT INFORMATION

- Dual power options; wired or battery powered.
- Motor **including Bluetooth capabilities**.
- Works directly with our Forest Connect App.
- Can be connected to the power grid with a power adapter.
- Application width: min. 53 cm (20.87") & max 5.80 meter (19').
- Available height: 3.50 meter (11.5').
- Maximum fabric weight per cord roll: 1 kg and total system 4 kg.
- Track finish: durable, high-quality aluminium with a powder-coated finish.
- Colour available: white.
- Equipped with Forest Link RF protocol.
- Charging motor takes 6-8 hours or until the blue light comes on.
- 6 month battery life (1 up & 1 down).
- 5 year warranty on motor.
- 2 Year warranty on the battery pack.

FOR USE IN

Hotels, offices, residences, boats or anywhere an efficient motorised Velcro track system for roman shades is required.

FEATURES

- Weight 409 gr/mtr
- Aluminium extrusion 6063 T5
- Size 33.3 x 36.7 mm (1.3" x 1.4")
- Colour available: white

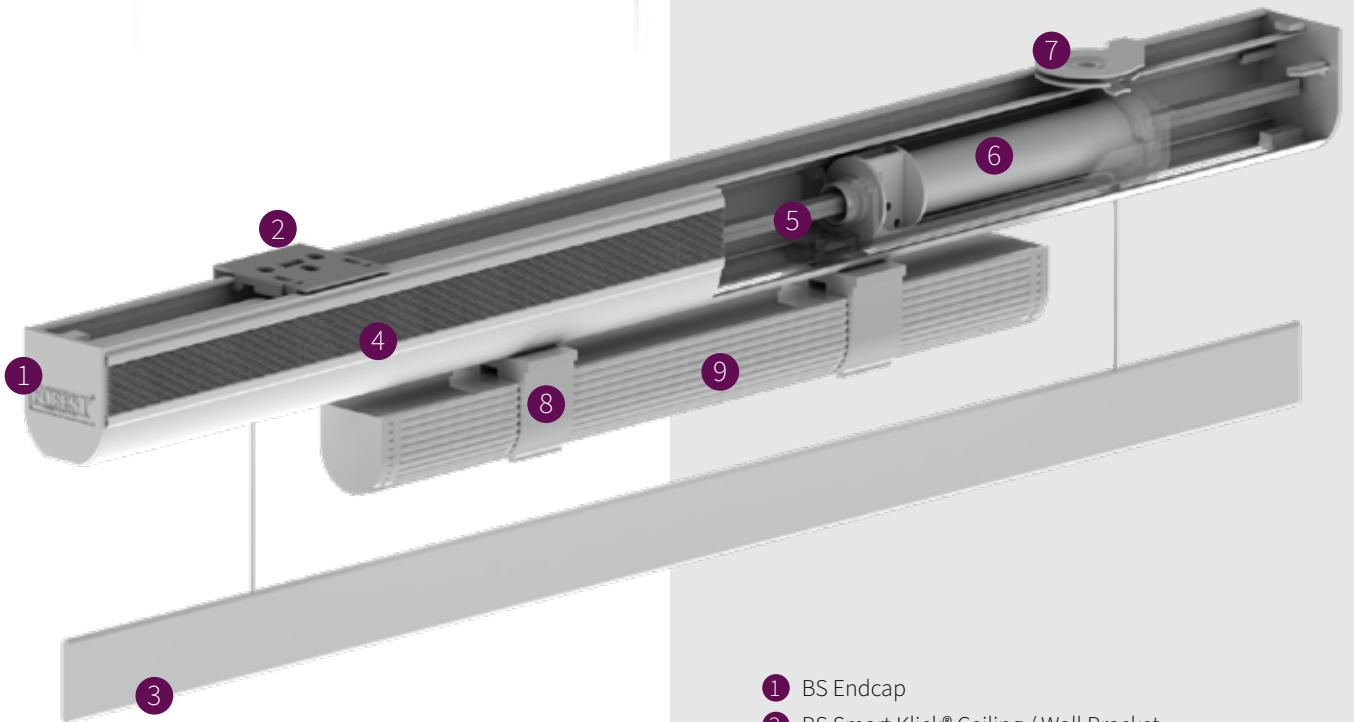
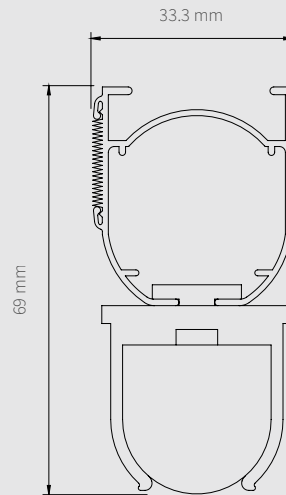

- 1 BS Endcap
- 2 BS Smart Klick® Ceiling / Wall Bracket
- 3 Counterweight bar 6 x 20 mm.
- 4 BS Track incl. Velcro Hook Tape
- 5 BS Rod 5x5mm
- 6 BS Quicklock Cord Roll
- 7 BS Ceiling bracket, swivel
- 8 Battery bracket
- 9 Battery pack
- 10 Bluetooth
- 11 Battery-powered BS Motor

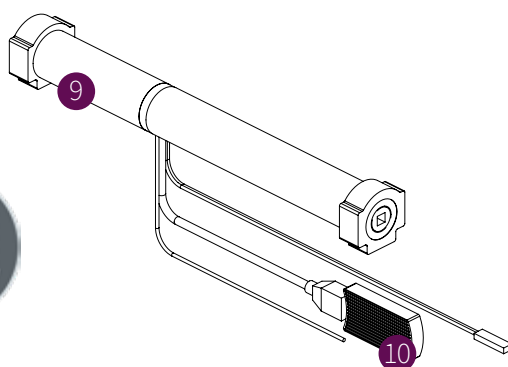

FOREST BLIND SYSTEM MAX - BS MAX®



To complement the manual range of the roman blind systems for heavier duty drapery, Forest introduces the Blind System Max®.

The Forest BS Max® is developed for taller windows and heavier fabrics. This roman blind system can go up to a height of 4.80 meter with a total weight of 13 kg. It comes with integrated velcro tape so that the fabric can be easily attached & removed.

CONTROL OPTIONS



CHAIN
CONTROL

PRODUCT INFORMATION

- Hand drawn roman blind system.
- For all types of medium and heavy weight draperies.
- Elegant shaped aluminium profile, with integrated Velcro hook tape.
- Application width: min. 38 cm & max 5.80 meter (19").
- Available height: 4.80 meter (15,75").
- Simple face-fix and top fix installation.
- Cords are easy to remove; very useful when washing or dry cleaning the fabric.
- Self-braking endless chain control units.
- Maximum fabric weight per cord roll:
4 kg and total system 13 kg.
- Colour available: white.
- Track finish: durable, high-quality aluminium with a powder-coated finish.
- 10 year warranty.

FOR USE IN

Hotels, offices, residences, boats, campers, planes or anywhere an efficient Velcro track system for roman shades is required.



FEATURES

- Weight 694 gr/mtr
- Aluminium extrusion 6063 T5
- Size 53.2 x 53.5 mm (2.0" x 2.1")
- Colour available: white

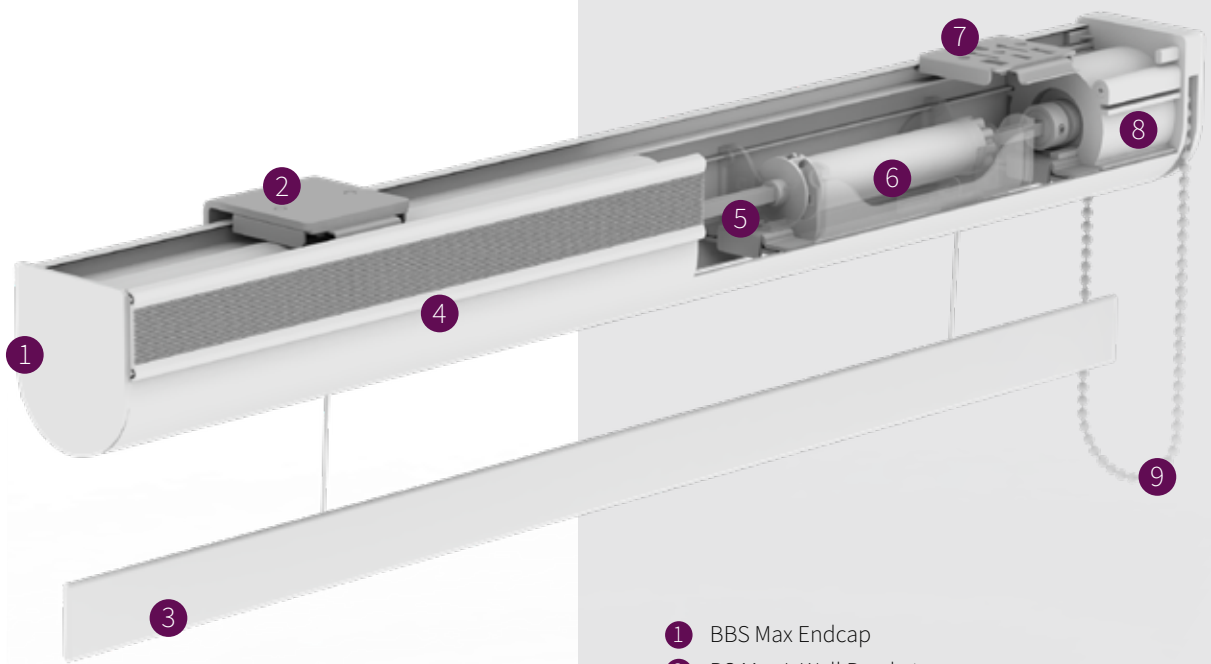
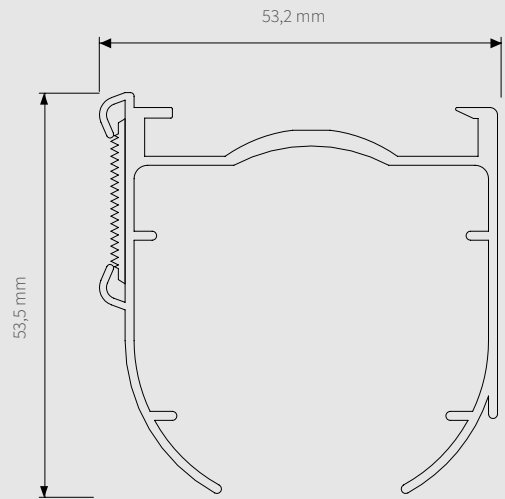

- 1 BBS Max Endcap
- 2 BS Max L-Wall Bracket
- 3 Counterweight bar 6 x 20 mm
- 4 BS Max Track incl. Velcro Hook Tape
- 5 BS Rod 5x5mm
- 6 BS Max Cord Drum
- 7 BS MaxHidden Ceiling Bracket
- 8 BS Max Control Unit 1:4
- 9 Chain

FOREST BLIND CONTRACT SYSTEM - BCS[®]



Another solution of Forest is the motorised roman blind 'BCS[®]-system', developed especially for taller window frames and heavier fabrics. The tubular motor in the system is 220 Volt and available in variable voltages as required. A powerful 121 Watt motor is standard, capable of lifting blinds of up to 13 kg; other motor types - capable of up to 26 kg - are available upon request. The cord coils can hold 5.5 meter of cord.

The Forest roman blind BCS[®] system is suitable for all current control systems and incorporates a unique, patented cord braking system. If, for any reason, the roll down action of a blind is obstructed, the motor automatically trips out to prevent the blind leaning and the cord breaking.

CONTROL OPTIONS



SMART HOME



APP CONTROL



REMOTE CONTROL

PRODUCT INFORMATION

- Motorised roman blind system.
- For all types of medium and heavy weight draperies.
- Elegantly shaped aluminium profile, with Velcro Hook Tape.
- Available width: 5.80 meter (19").
- Application width: min. 65 cm & max 5.50 meter (18").
- Simple and quick installation with Smart Klick[®] bracket.
- Cords are easy to remove; very useful when you want to wash or dry cleaning the fabric.
- Can be controlled by wall switch, remote control (high frequency).
- Easy to connect to building automation systems.
- Easy to connect with third party Apps (Apple Homekit or Google Assistant) by the Forest Wireless Connector.
- Cord Drums can be placed on every position in the profile.
- Maximum fabric weight per cord roll: 4 kg.
- Tubular motor also available with internal Multi receiver and electronic limit setting.
- Track finish: durable, high-quality aluminium with a powder-coated finish.
- Warranty Manual System: 10 year.
- Warranty Motorised System: 5 year.

FOR USE IN

Domestic and/or project market, or at any location where a high quality and smooth operated motorized blind system is requested.

FEATURES

- Weight 1092 gr/mtr
- Aluminium extrusion 6063 TS
- Size 63 x 74 mm (2.4" x 2.9")
- Colour available: white

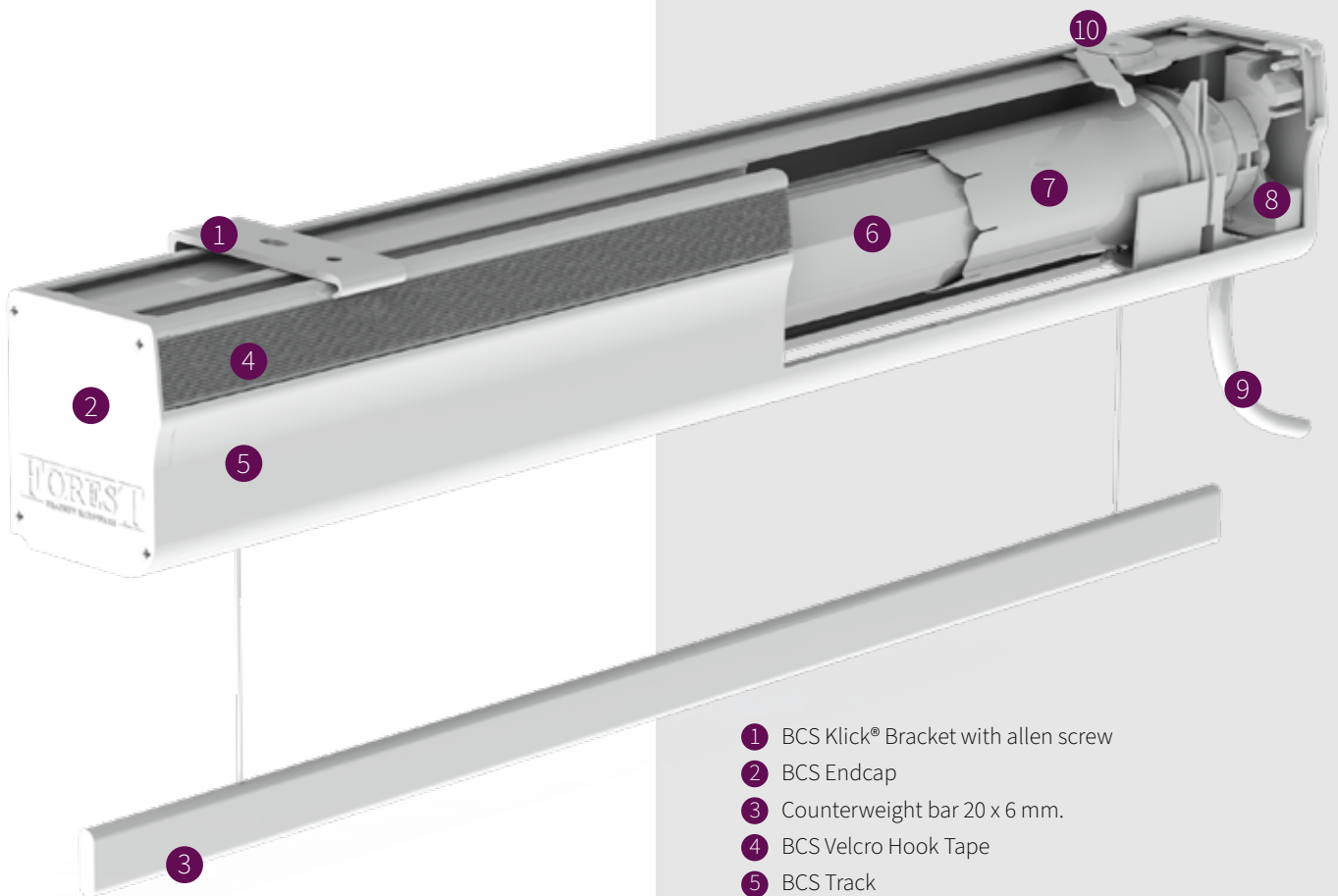
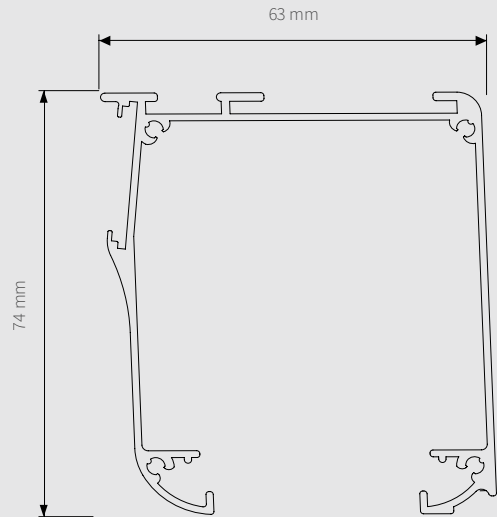

- 1 BCS Klick® Bracket with allen screw
- 2 BCS Endcap
- 3 Counterweight bar 20 x 6 mm.
- 4 BCS Velcro Hook Tape
- 5 BCS Track
- 6 BCS Tube 8-angular
- 7 BCS Cord Roll House Complete
- 8 BCS Centre Support
- 9 Forest Tubular Motor
- 10 Ceiling Swivel Bracket

FOREST BLIND CONTRACT SYSTEM - BCS[®]



SPECIFICATIONS

| Type | Strength | Speed | Weightload | Noise level | Internal Receiver | Control options |
|---------|----------|--------|------------|-------------|-------------------|---|
| 6/28/SQ | 6 Nm | 28 rpm | 13 kg | < 42 dB(A) | No | Home Automation / Building Automation |
| 5/20/EQ | 5 Nm | 20 rpm | 13 kg | < 40 dB(A) | Yes | Forest EasyTouch Series (Remote / Wireless Wall Switch) |

MOUNTING

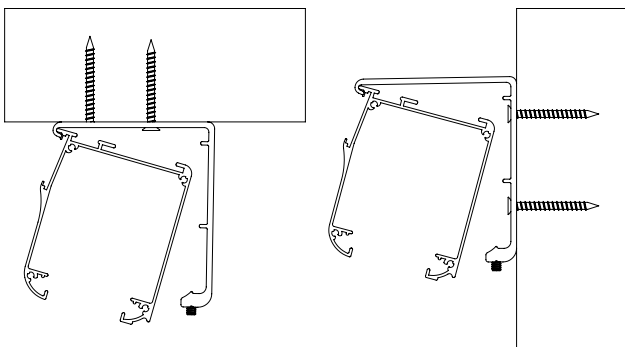

Wall and ceiling fixing is possible.

ADJUSTING MOTOR

The limit settings for the tubular motors can be done as follows:

- S motors, mechanically by means of an allen key.
- E motors, electronically by means of a Forest Remote or RF Wall Switch.

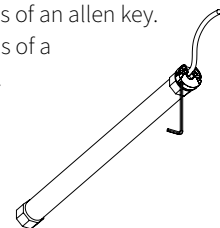



CONTROL OPTIONS

Our wide range of controls make finding a fit for your home even easier; controlling the curtains by hand, remote or even by building automation system. With the remote you can control the roman blinds in any position you like. Controlling the motorised roman blind system by your smartphone or tablet, you can create and schedule customised room scenes that allow your roman blinds to operate on their own throughout the day.

REMOTE CONTROL

We offer two different remote controls and a wall switch:



- EasyTouch remote control: Operates up to 6 systems, and unused channels can be deactivated
- Diamond Sense remote control: Available as a 15- or 2-channel remote control with an LED display.
- EasyTouch wall switch: A wireless 2-channel wall switch for fixed wall-mounted operation.

All models are available in white and black.

FOREST CONNECT APP



With the Forest Connect App you always have your curtain control at hand. You can easily swipe your curtains open or close. Simply set a timer to open or close the curtains at set times. Handy when you are not at home. Or let your curtains open and close automatically with sunrise and sunset. The Forest Connect app works with the tubular motor for BS and is available in the App Store and Google Play.

CONNECT WITH HOMEY APP



Easily connect all Forest tubular motors with Homey and control and automate them, together with your other smart devices, in the Homey app. Homey is supporting the original RF protocol as well the RF Link protocol, seamless smart-home compatibility is part of the experience from day one.

BUILDING AUTOMATION / HOTEL CONTROL

The BCS® System can be connected to any Building Automation system, by relay control.

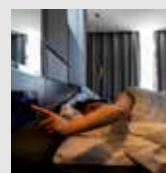









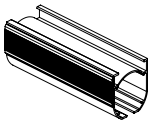



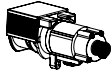
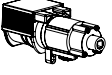

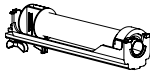
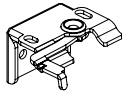
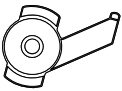
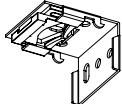
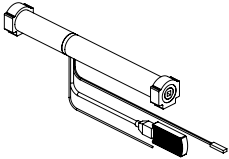

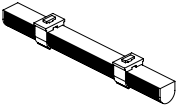
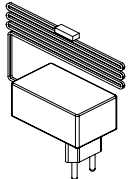

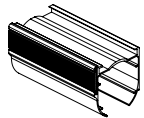
FOREST® BCS WORKS WITH

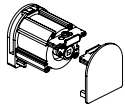
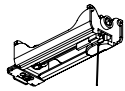
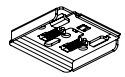
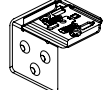
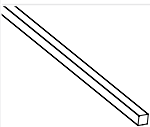

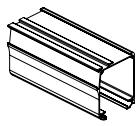





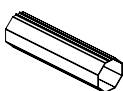
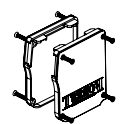
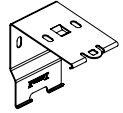
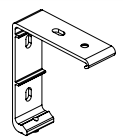

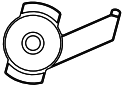
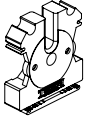
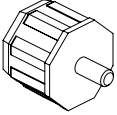
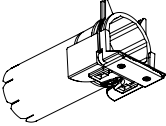
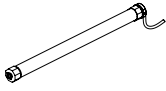
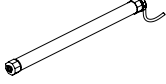
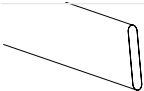

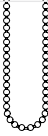





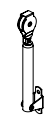

* Only works with actor.

Forest BCS® is compatible with many other Building Automation systems, thanks to its modular construction. A competitive advantage over other motorised drapery systems in the world!

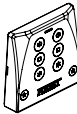
| BS MANUAL | BS MOTOR | BS BATTERY | BS-MAX | BCS | ARTICLE | PACKING UNIT | ART.NR | |
|-----------|----------|------------|--------|-----|---|----------------|-------------------|--------------------------|
| • | • | • | | |  <p>BS TRACK Extruded aluminium white powder coated, with Velcro hook tape on front of the track. Available length: 5,8 mtr. (19 Ft.)</p>  | 58 mtr./bundle | white | 3601001580 |
| | • | | | |  <p>BS CONTROL UNIT 1:1, incl. endcap Weight capacity 35 kg</p>  <p>BS CONTROL UNIT 1:4, incl. endcap Heavy duty, Self-braking. Operation by chain. Weight capacity 7.5 kg</p> | 100/box | white | 3611001011-L |
| | | | | • |  <p>CHILD SAFETY CONTROL UNIT 1:1 Child safe solution, incl. endcap Weight capacity 3,5 kg</p>  <p>CHILD SAFETY CONTROL UNIT 1.4 Child safe solution, incl. endcap Weight capacity 7,5 kg</p>  | 100/box | white | 3611001011 |
| | | | | • | | 100/box | white | 3611001000 |
| • | • | • | | |  <p>QUICKLOCK CORD ROLL incl. 3.5 mtr. cord (different color types cord available upon request, see for colour options BS/BCS Cord) without cord</p> | 100/box | white/transparent | 3642401350 |
| | | | | • | | | | 3642400000 |
| • | • | • | | |  <p>BS WALL BRACKET, SWIVEL Metal</p> | 100/box | white | 3663001000 |
| • | • | | | |  <p>BS CEILING BRACKET, SWIVEL</p> | 100/box | white | 3661000000 |
| • | • | | | |  <p>BS SMART CLICK WALL / CEILING BRACKET Metal</p> | 100/box | white | 3662000000 |
| | | • | | |  <p>BS MOTOR WITH BLUETOOTH SET Excl. Battery Pack, incl. Bluetooth Dual power options: can be cable-powered or battery-powered Features Original RF Protocol</p>  | 1/set | | 3636000010 |
| | | • | | |  <p>BS MOTOR BATTERY PACK WITH USB CABLE TYPE C (3 MTR) Incl. 2 mounting brackets for on the BS Track. Incl. USB to USB-C cable.</p> | 1/set | | 3636000002 |
| | | • | | |  <p>BS BATTERY MOTOR 12V ADAPTOR PLUG (1.5 MTR) + EXTENSION (2.4 MTR) EU To be used as a charging set or for continuous power supply.</p> | 1/set | EU UK | 3636000004 3636000005 |

| BS MANUAL | BS MOTOR | BS BATTERY | BS-MAX | BCS | ARTICLE | PACKING UNIT | ART.NR |
|-----------|----------|------------|--------|-----|--|---|---------------------------------|
| | | | • | |  <p>BS MAX TRACK Extruded aluminium white powder coated, with Velcro hook tape on front of the track Available length: 5,8 mtr (19 Ft.)</p> | 46,4 mtr./ bundle  | white 3710001580 |
| | | | • | |  <p>BS MAX CONTROL UNIT 1:4 with endcap</p> | 50/box | white 3711001014 |
| | | | • | |  <p>BS MAX CORD DRUM incl. 4,8 mtr. cord</p> | 50/box | white/transparent 3711000480 |
| | | | • | |  <p>BS MAX HIDDEN CEILING BRACKET</p> | 50/box | white 3711000000 |
| | | | • | |  <p>BS MAX L-WALL BRACKET</p> | 100/box | white 3711000001 |
| • | | | • | |  <p>BS ROD 5X5 MM ALUMINIUM Aluminium 5 x5 mm (0,20" x 0,20") Available length: 5,8 mtr (19 Ft.)</p> | 10/bundle | 3630000580 |
| • | | | • | • |  <p>FIBEROD 6 meter length 4mm diameter</p> | 600 mtr. / bundle | 3535301600 |
| | | | | • |  <p>BCS TRACK Extruded aluminium white powder coated Available Length 5,80 mtr (19 Ft.)</p> | 500 mtr./roll     | white 3416101000 |
| | | | | • |  <p>BCS VELCRO HOOK TAPE 25 mm height. 1,20 meter length</p> | 1/box | white 3416500004 |
| | | | | • |  <p>BCS TUBE 8-ANGULAR Length 5,80 mtr (19 Ft.)</p> | 1pc | white 3416102000 |
| | | | | • |  <p>BCS ENDCAPS LEFT/RIGHT</p> | 25 sets/ box | white 3416201000 |
| | | | | • |  <p>BCS EASY MOUNT WALL / CEILING BRACKET For wall and ceiling fixing.</p> | 25/box | white 3416301010 |
| | | | | • |  <p>BCS MOUNTING BRACKET WITH ALLEN SCREW For wall and ceiling fixing.</p> | 25/box | white 3416301020-B |

| BS MANUAL | BS MOTOR | BS BATTERY | BS-MAX | BCS | ARTICLE | PACKING UNIT | | ART.NR |
|-----------|----------|------------|--------|-----|---|--|--|--|
| | | | | |  CEILING SWIVEL BRACKET For ceiling fixing. | 100/box | white | 3818200450 |
| | | | | |  BCS CENTRE SUPPORT Dimension: 51 x 56 mm. | 25/box | | 3416500000 |
| | | | | |  BCS TUBE SUPPORT 8-ANGULAR To be placed on the open end of the 8 angular tube. | 25/box | | 3416500003 |
| | | | | |  BCS CORD DRUM COMPLETE Incl. 5.5 mtr white cord. | 25/box | | 3416500002 |
| | | | | |  FOREST BMS TUBULAR MOTOR Ø 35MM 6/28/SQ For Home/ Building Automation | 1/box | 230v/50hz 6nm/28rpm | 3416700012 |
| | | | | |  FOREST LINK TUBULAR MOTOR Ø 35MM WITH INTERNAL RECEIVER 5/20/EQ For use with Forest EasyTouch Series Remote Control/Wall Switch or Homey App | 1/box | 230v/50-60hz 5nm/20 rpm/EQ | 3416700117 |
| | | | | |  COUNTER WEIGHT BAR 6 MTR | 60 mtr./bundle 60 mtr./bundle 90 mtr./bundle 30 mtr./bundle | 6 x 20 mm white 3 x 25 mm white 3 x 40 mm white 5 x 25 mm white | 3501701600 3801400600 3801401600 3801402600 |
| | | | | |  ROMAN BLIND CHAIN 6 MM PITCH METAL STAINLESS STEEL Not compatible with the child safety control units | roll 1/bag | rol 150 mtr 1.50 mtr (drop=0.75 mtr) 2.00 mtr (drop=1.00 mtr) 2.50 mtr (drop=1.25 mtr) 3.00 mtr (drop=1.50 mtr) 3.50 mtr (drop=1.75 mtr) 4.00 mtr (drop=2.00 mtr) 4.50 mtr (drop=2.25 mtr) | 3670008100 3670008150 3670008200 3670008250 3670008300 3670008350 3670008400 3670008450 |
| | | | | |  ROMAN BLIND CHAIN 6 MM PITCH METAL Not compatible with the child safety control units | roll 1/bag | rol 150 mtr 1.50 mtr (drop=0.75 mtr) 2.00 mtr (drop=1.00 mtr) 2.50 mtr (drop=1.25 mtr) 3.00 mtr (drop=1.50 mtr) 3.50 mtr (drop=1.75 mtr) 4.00 mtr (drop=2.00 mtr) 4.50 mtr (drop=2.25 mtr) 5.00 mtr (drop=2.50 mtr) 6.00 mtr (drop=3.00 mtr) | 3670003100 3670007150 3670007200 3670007250 3670007300 3670007350 3670007400 3670007450 3670007500 3670007600 |
| | | | | |  ROMAN BLIND CHAIN 6 MM PITCH METAL MATT BLACK Not compatible with the child safety control units | roll | 1.00 mtr | 3670006100 |
| | | | | |  BS ENDLESS CHAIN 6 MM PITCH WHITE Compatible with the child safety control units | 1/bag | 1.00 mtr (drop=0,50 mtr) 1.50 mtr (drop=0.75 mtr) 2.00 mtr (drop=1.00 mtr) 2.50 mtr (drop=1.25 mtr) 3.00 mtr (drop=1.50 mtr) 3.50 mtr (drop=1.75 mtr) 4.00 mtr (drop=2.00 mtr) 4.50 mtr (drop=2.25 mtr) 5.00 mtr (drop=2.50 mtr) 6.00 mtr (drop=3.00 mtr) | 3670002100 3670002150 3670002200 3670002250 3670002300 3670002350 3670002400 3670002450 3670002500 3670002600 |
| | | | | |  CHAIN JOINTING PLIER For joining two ends of the metal chain together | 1/box | | 3675900001 |

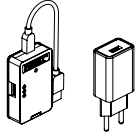
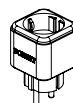
| BS MANUAL | BS MOTOR | BS BATTERY | BS-MAX | BCS | ARTICLE | PACKING UNIT | ART.NR |
|-----------|----------|------------|--------|-----|---|---|--|
| • | | | • | |  CORD/CHAIN WALL MOUNT SAFETY BOX SINGLE | 25/box | 3645702000 |
| • | | | • | |  TENSION PULLEY | 25/box white | 1030501000 |
| • | | | • | |  CORD/CHAIN WEIGHT DESIGN | 10/box white grey black | 3030701000 3030703000 3030706000 |
| • | | | • | • |  LOOP TAPE 20MM To be fixed onto the curtain fabric | 25 mtr./roll | 3816202020 |
| • | | | • | • |  ROMAN BLIND CORD For use in combination with Cord Roll Support / Cord Drum. Thickness: 1.3 mm. | 500 mtr/roll white (other colours available upon request: white, corn, grey, off-white, black, steel grey, old pink, mocca, beige, moss, salmon, aubergine, green, pink) | 3645001000 |
| • | | | • | • |  SNAP CORD FIXER For easy adjustment of the bottom side of the blind | 100/box transparent | 3647001001 |
| • | | | • | • |  SNAP CORD FIXER CHILD SAFETY  | 100/box transparent | 3611001001 |
| | • | | | • |  FOREST EASYTOUCH WIRELESS WALL SWITCH 2 channel LED Equipped with the original RF protocol and Forest Link® Dimensions : 8.3 x 8.3 x 1.9 cm  | 1/box matt white matt black | 5201001480 5201006480 |
| | • | | | • |  FOREST EASYTOUCH REMOTE CONTROL 6-channel Features the original RF protocol & Forest Link® protocol. Excl. Wall holder  | 1/box matt white matt black | 5201081006 5201086006 |
| | • | | | • |  FOREST EASYTOUCH WALL HOLDER Only suitable for EasyTouch remote control | 1/box transparent | 5201080000 |
| | • | | | • |  FOREST DIAMOND SENSE REMOTE CONTROL 2-15 channel with LED display Integrated timer included, original RF Protocol Incl. magnetic wall holder | 1/box white black | 5201091470 5201086470 |
| | • | | | • |  FOREST WIRELESS CONNECTOR Incl. 15 cm USB cable. Always in combination with USB-adapter. Can be ordered separately as Forest Wireless Connector USB-adapter. One way transmitter to integrate system in Domotic System. To control by third apps like Google Home, Amazon Alexa or Apple Homekit use a (third-party) smart plug. Works only with original RF protocol and not with Link RF Protocol. | 1/box white USB-adapter EU USB-adapter UK USB-adapter AU USB-adapter US | 5201002270 5201002271-EU 5201002271-UK 5201002272-AU 5201002274-US |
| | • | | | • |  SMART PLUG WHITE The Smart Plug allows App control via the Forest Connect App (the Forest Wireless Connector is required) | 1/box EU Other | 5201001952-EU Upon request |

Forest Group is specialised in the development, production and supply of highly innovative curtain tracks and window coverings. We offer different curtain track solutions especially made for the hospitality industry. Whether you choose for our motorised curtain tracks or rods, blinds or manual curtain tracks your client will experience 'the Forest Factor'. Which stands for a unique combination of smooth hanging curtains, comfortable luxury and optimal ease of use.

THE WORLD BEHIND YOUR CURTAINS

More than thirty years ago it started with a flexible aluminium system, better known as Forest KS® system. The range was expanded at a rapid pace, always focusing on functionality and quality. The technologies conquered the world. Hotels all over the world are satisfied users of Forest systems and even iconic hotels like the Palazzo, the Venezian, both in Las Vegas and the mega hotels in Dubai were equipped with kilometers of tracks from Forest Group.

Forest Group supplies its products in more than 100 countries worldwide and has sales offices in The Netherlands, United States, China, United Arab Emirates, United Kingdom and Poland, ensuring a global availability of our products.

SOME WELL-KNOWN AND RECOGNISED FEATURES OF THE FOREST GROUP CURTAIN TRACK SYSTEMS ARE:

- **High-quality standards:** We guarantee a long lifespan.
- **Comfort and silence:** Curtains open and close silently, creating a serene and comfortable environment.
- **Adds style to windows:** Always perfectly hanging curtains thanks to our systems, including motorised solutions.
- **Smart integration:** Controllable via app, voice, and home automation systems for ultimate convenience.
- **Sustainability:** We use a minimum of 75% recycled aluminium.
- **Unique warranty:** 10-year warranty.
- **Unieke garantie:** 10 jaar garantie.



Curtain engineering by Forest